

Bu Resim MESA OTO ELEKTRİK LTD.ŞTİ'nin malıdır. Şirket Yetkililerinin izni olmaksızın kopya edilemez, üzerinde değişiklik yapılamaz. This image MESA AUTO ELECTRIC LTD 's are property. Can not be copied without the consent of the company authorized, any changes can be made.

PARÇA KODU PART CODE	PARÇA ADI PART NAME	s ÖLÇÜSÜ (KALINLIK) s MEASURE (THICKNESS)	Malzeme Material	Kaplama / Coating		
				SN	AG	Nİ
TŞ 2407 DP	1 NO 2.TERMINAL Ø2.7 =DP=	0.45±0.05	(CuZn30) Pirinç / Brass	-	-	-
TŞ 2407 RP	1 NO 2.TERMINAL Ø2.7 =RP=	0.45±0.05	(CuZn30) Pirinç / Brass	-	-	-
TŞ 2407 RPK	1 NO 2.TERMINAL Ø2.7 =RPK=	0.45±0.05	(CuZn30) Pirinç / Brass	+	-	-
TŞ 2407 RÇN	1 NO 2.TERMINAL Ø2.7 =RÇN=	0.50±0.05	Paslanmaz Sac(430)	-	-	-

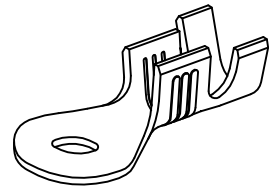

Perspektif
Perspective

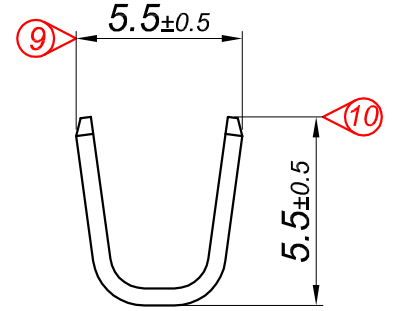
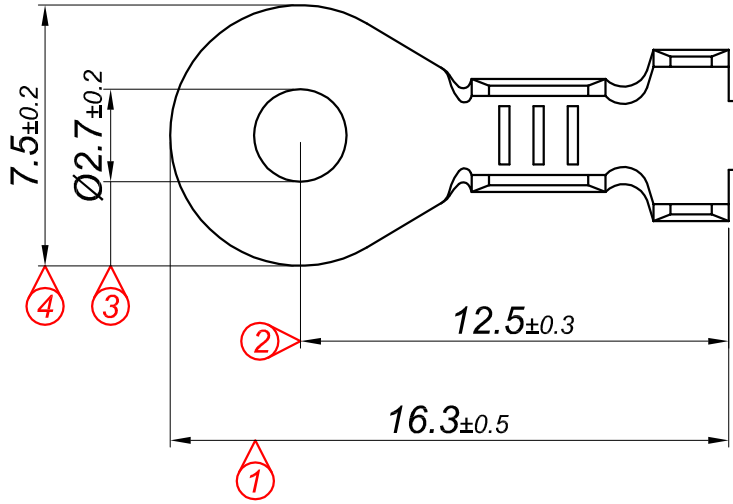
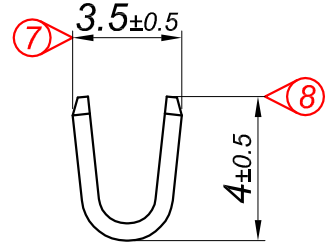
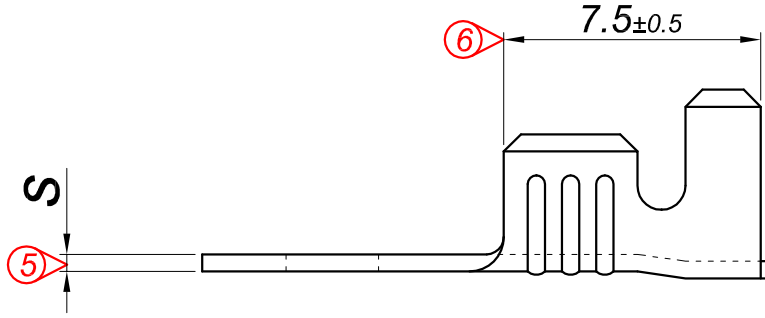
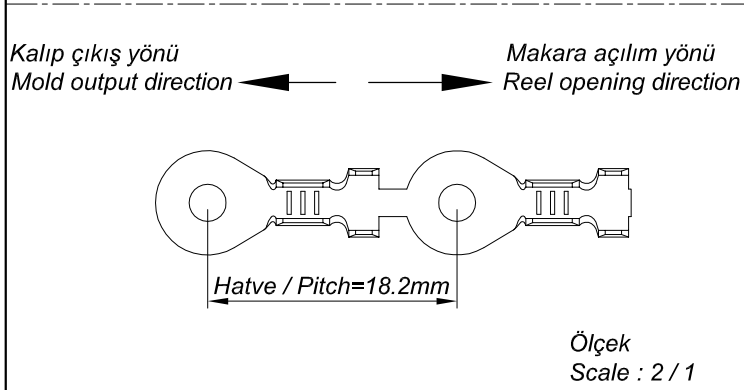

Kablo Kesiti
Wire Section : 1 - 2.50 mm²

Resim üzerinden ölçü almayınız
do not measure on drawing

Tarih / Date	19.07.2013	İmza /Signature	Ölçek /Scale		
Çizen / Desing	M.Yağcı		5 / 1	01	ÇİFTLİ KALIP YAPILMIŞTIR.
Onay / Approval	S.Gölcük			No	Değişiklik / Revision
					Tarih/Date



Parça Adı:
Part Name

1 NO 2.TERMINAL Ø2.7

Parça Kodu:
Part Code

TŞ 2407